

Design and Implementation of Single Sided Deafness Treatment Device

Israa Saeb Mohammed

Al-Hussain University College Medical Instrumentation Techniques Engineering Department

Rana Hameed Jassim

University of Kerbela, Collage of Engineering, Department of Biomedical Engineering

Received: 2024 25, Jul

Accepted: 2024 21, Aug

Published: 2024 26, Sep

Copyright © 2024 by author(s) and BioScience Academic Publishing. This work is licensed under the Creative Commons Attribution International License (CC BY 4.0).



Open Access

<http://creativecommons.org/licenses/by/4.0/>

Annotation: This project aims to design and implement a device that helps people who suffer from unilateral deaf problems through, where this device is installed on the affected ear of the person and then the device receives the sounds coming from the surrounding environment and then transfers them to the healthy ear on the other end and this is done using technicians It's called CROS (Contralateral Routing of Signals). With a CROS system, you wear hearing aids on both ears, even though you can't hear in one of them. The sound detected by the aid on the "bad ear" is transmitted directly to the aid on the "good ear" side. This gets rid of the "head shadow" effect.

1.1 Introduction

Globally, 466 million people suffer from disabling hearing loss, and 34 million of them are children.

It is estimated that by 2050 more than 900 million people will experience a hearing loss.

Hearing loss may be due to genetic causes, complications at birth, certain infectious diseases, some types of chronic ear infections, use of certain drugs, exposure to excessive noise and aging.

60% of childhood hearing loss can be prevented through public health action _ billion young people (ages 12 to 35) are at risk of hearing loss from noise exposure in recreational contexts.

_Untreated hearing loss causes \$ 750 billion in annual global costs. Interventions. to prevent, identify and respond to hearing loss are costeffective and can have significant benefits for individuals.

Hearing aids, cochlear implants and other assistive devices may benefit from people with hearing loss. Captioning and sign language; And other forms of educational and social support.

More than 5% of the world's population – 466 million people – suffer from disabling hearing loss (432 million adults and 34 million children). It is estimated that by 2050 more than 900 million people – or one in ten – will experience a hearing loss. Impaired hearing loss refers to a loss of hearing greater than 40 dB in the ear of best hearing for adults and hearing loss greater than 30 dB in the ear of best hearing for children. Most of these people live in low- and middle-income countries.

About a third of people over the age of 65 suffer from disabling hearing loss. Prevalence in this age group is highest in southern Asia, the Asia-Pacific region and sub-Saharan Africa.

Infectious diseases, such as meningitis, measles, mumps, and chronic ear infections, can lead to hearing loss. Other common causes include exposure to noise, ear infections, aging, and medication use

Ototoxic. Half of all deafness and hearing impairment can be prevented through prevention, early diagnosis, and management. The quantities of hearing aids currently produced meet only 11% of global needs. In this paragraph, we will talk about the causes of hearing loss that may eventually lead to total hearing loss or deafness.

1.2_Problem Statement

Many people who suffer from unilateral deafness suffer from major problems, as it is difficult for them to hear the sounds coming from the side of the injured ear, and this causes difficulty in communicating between the affected person and other people, and for this reason many traditional methods have been made to help people with unilateral deafness in solving This is the problem, but most of these solutions were suffering from defects represented in their large or heavy size, as well as their high cost.

1.3_Aim of Work

In this research, we proposed building a model to help people with a one-sided hearing problem, by designing a device consisting of two parts, a sending circuit and a receiving circuit. Where the transmitter circuit is installed on the healthy ear of the affected person, where this circuit receives the sound from the speaking person and then sends the received sound to the healthy ear of the affected person. Thus, this project helps in solving the problem of people who suffer from the problem of unilateral deafness.

2.1_The History of Hearing Aids:

Hearing loss is not a new condition. People have been suffering from it for centuries. Up until the 16th century, it was commonly accepted that individuals with hearing loss also suffered from multiple other disabilities; this led to them being heavily discriminated against. It was not until a Spanish monk named Pedro Ponce taught a nobleman's deaf sons how to read, write, speak and do math that this fact was disproven.

When Was the First Hearing Device Invented?

The ear trumpet was invented in the 17th century and is considered the first device used to help the hearing impaired. These trumpets came in a number of shapes and sizes and were made of everything from sheet iron to animal horns.

The next advancement did not appear until the late 18th century with the invention of the collapsible ear trumpet. Frederick C. Rein was the first to commercially produce these trumpets in 1800. In order to make the devices less noticeable, Rein created acoustic headbands, which hid the hearing devices within the user's hair.

What About the First Hearing Aid?

The first hearing aid was designed thanks to Alexander Graham Bell's 1876 invention of the telephone, which included technology that could control the loudness, frequency and distortion of

sounds.

The first electric hearing aid was invented in 1898 by Miller Reese Hutchison. His design used an electric current to amplify weak signals. In 1913, the world was introduced to the first commercially manufactured hearing aids. These devices were cumbersome and not very portable. In the 1920s vacuum

- tube hearing aids were produced; these tubes were able to turn speech into electric signals and then the signal itself was amplified.

The idea of miniaturization was ushered in with other technological advances spurred by WWII; this was crucial to the advancement of hearing aids. The transistor was invented in 1948. Transistors were able to replace the vacuum tubes in previous models of hearing aids and were smaller, needed less battery power and had less distortion.

The microprocessor and the multi-channel amplitude compression were created in the 1970s. The microprocessor brought miniaturization to a new level and the compression ushered in the use of digital technology.

From there, hearing aids began evolve at a steady clip. The 1980s saw the creation of high-speed processors and microcomputers. The 1990s saw the appearance of the first all-digital hearing aid. And the 2010s brought the idea of Bluetooth enabled devices into the mix.

2.2– Hearing aid for hearing impairment:

These techniques are used in the case of mild, moderate or severe hearing impairment, but with the integrity of the auditory nerve, and they are only magnifying tools, as they are designed to enlarge or clarify sounds. And there are many of these devices available in the global market, and we will mention the most important models available according to the modernity of their technologies .

2.2.1- Invisible Hearing Aids:

Due to the technological progress that is happening day after day, medical companies have reached the production of hearing aids that can be placed inside the ear so that it becomes invisible to the onlookers.

However, this technology is still under development and is currently only suitable for patients with mild to moderate hearing loss.

In addition, it is the most expensive of all hearing aids, ranging from \$ 3000 to \$ 3700. Figure (2) illustrates one of these models produced by Strakey itself.

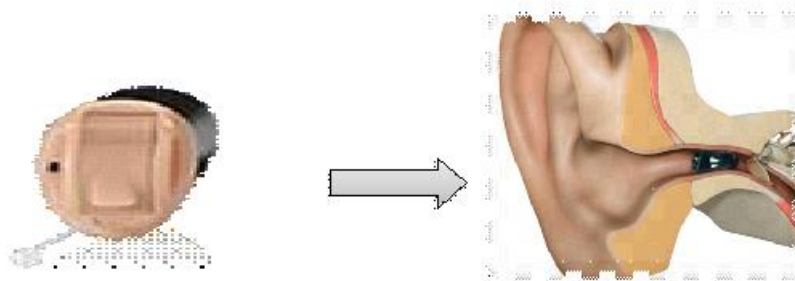

Figure 2.2: Invisible Hearing Aids

2.2.2-Traditional Hearing Aids:

It is the most widespread among the previous types, as they all have the same principle, which is to amplify the sound, but differ from each other in their form and in some of their specifications,

such as the number of sound channels that they use, the quality of the sound, the range of frequencies that a nomplify them

... etc.

They range in price from \$ 20 to \$ 500.



Figure 2.3: shows some types of these aids for different manufacturers.

2. 2.3_Related hearing aids with Iphone phones :

It is the latest in hearing support technology for people with hearing impairment, as these small devices are distinguished by the presence of wireless communication technology with the Iphone devices only, and thus enable its users to answer the phone using it, or listen to music through it .

Software technologies have also been utilized to improve sound quality and efficiency . But it has a negative, which is its high price, as it ranges from \$ 2500 to \$ 3000

2.3_ compensation for hearing loss (deafness):

The hearing loss is either a sensorineural Hearing Loss related to the inner ear) such as damage to the sensory cells in the helix or it is a conductive design. Hearing Loss has to do with the middle ear, as the result of problems in it is that the sound is not transmitted to the inner ear

(Such as perforation of the tympanic membrane, for example) and this type of deafness

It can be treated and is not a medical problem. Or that the mixed hearing loss or neural hearing loss is a result of damage or death of the auditory nerve, and there is no effective and guaranteed solution to treat this condition.

Emphasis will be placed on the first, "sensorineural" condition, which leads to either severe hearing loss that the previous aids are not helpful or to complete deafness (in one or both ears).

Where the auditory residues are insufficient, since the auditory sensory nerve capillaries in the cochlea have been damaged or deformed, the sound did not reach the auditory nerve, and there are limited techniques that will be talked about to treat this condition.

2.3.1_Cochlear implant technique:

(Suitable for a case of deafness of one or both ears, a condition of the integrity of the auditory nerve)

This technology is known as the artificial snail, and it is one of the means provided by the development of scientific research in recent years, in order to help the deaf to overcome their disability and facilitate their integration into society, which is the replacement of the complex human system of hearing technology with a new system based on an advanced device that combines technology Simple and information processing, it increases the accuracy of children's voice perception, slightly increases their ability to speak, and gives them the skills to communicate with their social environment.

This system consists of a small device that is placed behind the ear called the Audio Processor, an Implant implanted under the skin of the head in a surgical procedure, and a coil coil is attached to

the sound processor, which is attached to the head on the implant area by the force of magnetic attraction. Figure (5)



Figure 2.4: The external parts of the industrial helix system

Thus, the sound signals are sent from the sound processor to the implant inside the head via this coil.

There is an array of soft and flexible electrodes that are inserted into the cochlear during the surgery, in order to stimulate the largest possible number of nerve fibers, and the deeper the electrodes are inserted, the more stimulating the entire range of frequencies within it. Consequently, the sound signal passes directly to the auditory nerve, bypassing damaged areas of the cochlea.



The microphone in the sound processor captures the sound waves, then the sound processor digitally analyzes and encodes the sound and converts it into a special type of encoded signal to transmit it to the implant through the coil.

Then the implant generates electrical pulses from the encoded signals, and these pulses are transmitted through the electrode array to the appropriate electrode contact point within the helix and according to the frequency of the received wave. Figure 2.5: The mechanism of sound transmission in an industrial helix Then the auditory organ picks up these impulses and sends them to the auditory region of the brain to be perceived as sounds.



Figure 2.6: The transmission of sound waves through the auditory nerve But what must be mentioned in this regard is that this type of technology has its drawbacks, which are the high risk of dealing with the most dangerous part of the human body, which is brain surgery, in addition to the great cost of performing it.

2.3.2_Bone Conduction Implants:

(Suitable for Single-Sided Deafness (SSD) This technique is used in the case of conductive deafness, which is caused by problems in the middle and outer ear, or in the case of sensorineural deafness of one of the two ears, as the principle of this method depends on receiving sound waves through A sound processor installed on the head and then transferred to a subcutaneous implant using the same inductive method in paragraph (1-2), but instead of the implant sending it to an electrode array, it converts these waves into mechanical/acoustic vibrations that are transmitted through the skull bones to the auditory nerve in the healthy ear.

Figure (7) shows one of the devices using this technology manufactured by MED-EL itself.



The external part of the device The internal part of the device Figure 2.7: The Bone Conduction Implant Technique

2. 3.3- Cross-Side Signal Redirection (CROS):

Suitable for Single-Sided Deafness (SSD) which is the method used in this project, which depends on Receiving audio signals from the deaf ear and sending them to the acoustic receiver on the healthy ear, i.e. transmitting sound from the deaf ear to the opposite side Where the healthy ear is (Signal of Routing Contralateral).

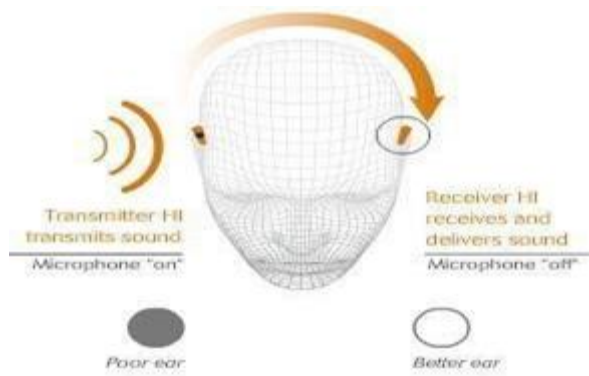

There are two methods for this technique: 1 (Wire CROS). 2(The modern wireless CROS method).

Figure 2.8: CROS Technology.



Figure 2.9: RNID Wire CROS

It should be mentioned that the companies that produce this technology devices are very limited around the world, and currently the wireless method is limited to only one company in the world, which is the Swiss company Phonak , and Figure (10) shows one of the aforementioned company's wireless CROS technology .



FM Receiver



FM Transmitter

Figure 2.10: Phonak wireless CROS device

2.4_Types of deafness and hearing impairment:

Hearing impairment is relatively common among children, and up to 1.9% of children suffer from a problem with hearing, and there is permanent impairment of hearing in more than one child in every 1000 children who undergo tests for hearing impairment, whether they have symptoms or

without any Syndrome. Deafness is the complete loss of the ability to hear from one or both ears, and there are several classifications and divisions of hearing impairment and deafness. Some of them divide it into a genetic and non-hereditary type, as if there is weakness affecting the nerve and the cochlea, a sensorineural hearing impairment is called, and if it is in the tympanic or middle ear, then it is called a conductive auditory impairment, and there may be a mixture between these two types and there is a type resulting from A problem in the center of hearing.

2.4.1- Conductive hearing impairment:

It results from a defect in the outer or middle ear with an intact inner ear. And lead to a problem in “delivering” sound “to the inner ear, and its causes include:

- 1) obits media.
- 2) Fluid collects in the ear.
- 3) Ear blockage due to wax.
- 4) Inflammation or infection of the tympanic membrane.

(Otosclerosis) weakened fossils in the middle ear due to growth of some surrounding ossicles.

3- MATERAL and Methods

This project consists of two circuits:

_a transmitter circuit.

_a receiving circuit.

3.1-A transmitter circuit consists of:

3.1.1– a microphone to pick up sound

3.1.2 – Max 2606: It gives a frequency range between [70-150] MHz, which is the required field to work.

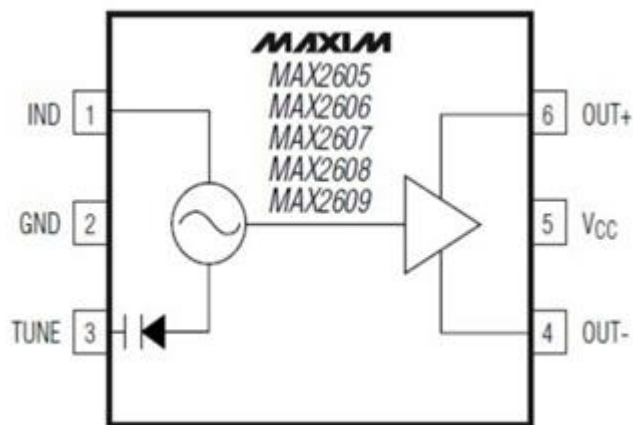

Figure 3.2: Integrated Circuit MAX2606

3.1.3_The LM4872 amplifier: is a micro SMD element that is characterized by its low power consumption, accurate size, and the ability to control signal gain.

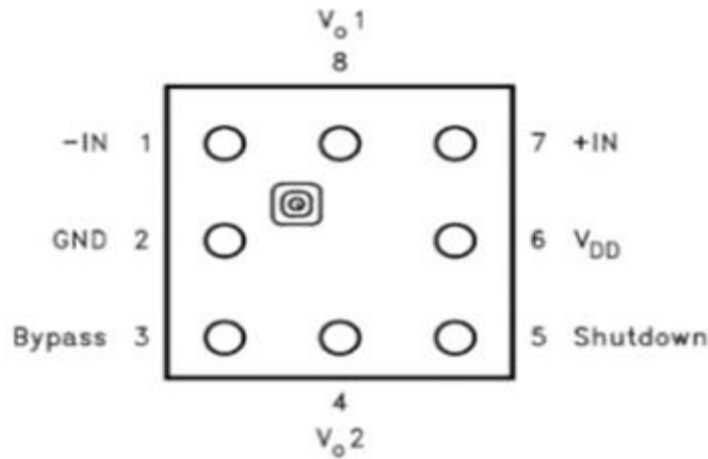

Figure 3.3 Integrated Circuit LM4872

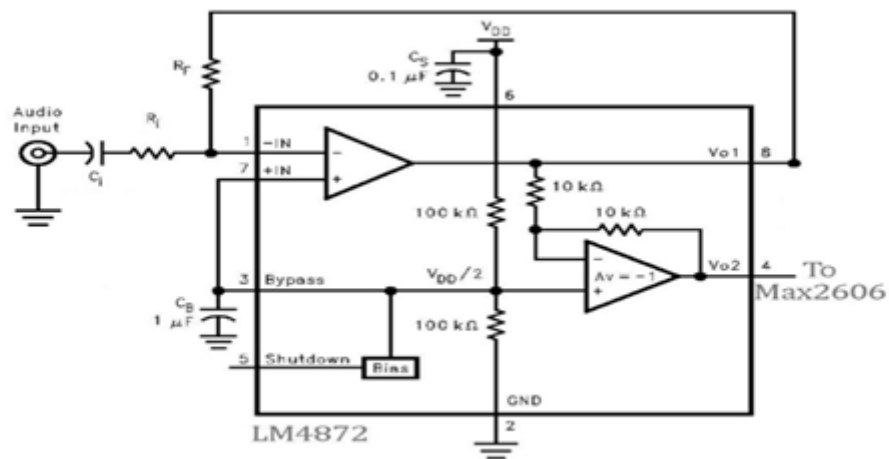

Figure 3.4: The internal structure of the audio amplification circuit LM4872

3.1.4– feed source.

3.1.5 – resistors, capacitors, inductors.

3.2-the circuit mechanism

in this circuit The desired frequency is chosen by choosing the value of the external inductor connected to pin 1 in the Max and pin 2 is grounded and about The way of the data sheet that is placed How to choose the appropriate inductor in the figure below.

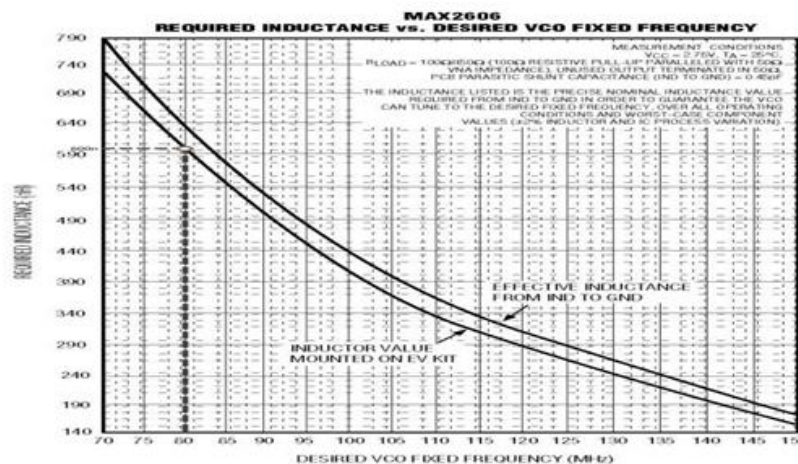

Figure 3.5: Data sheet

Feed the circuit by connecting a 2.7v battery to pin 5 in the integrated circuit, with capacitors in parallel, one of them 1mf and 0.01mf, called bypass capacitor. The purpose is that if a large current is drawn for a moment, the supply voltage will vibrate from the original value at this moment, and here the two capacitors are not Only the circuit allows the passage of this vibration, but it discharges its stored charge and presents it to the circuit in that short moment. The microphone or the audio receiver has been used as an audio amplifier to amplify the sound emitted by it. Then the amplified sound is filtered by HPF by controlling the R_i and c_i in it. For this circuit, the energy released must be very small, so that it is suitable and sufficient to pass from the deaf ear to the healthy ear, that is, over a very small distance.

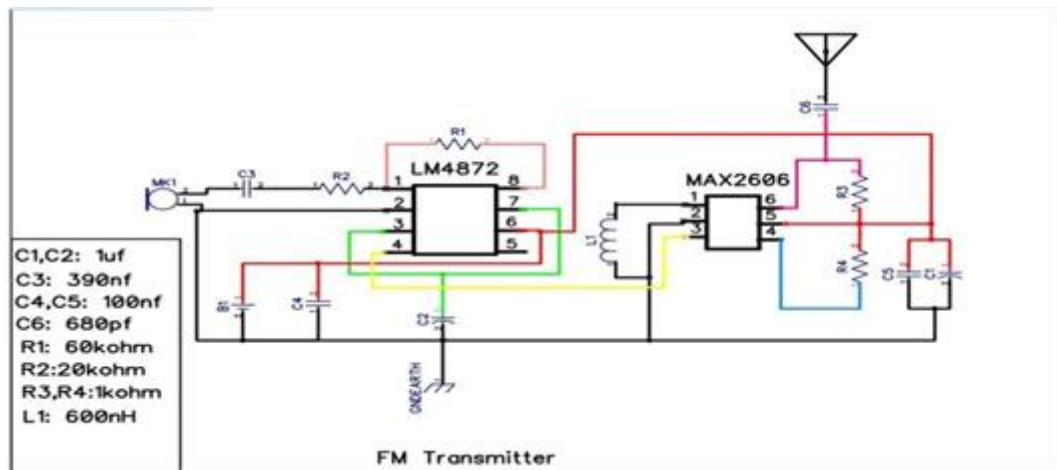
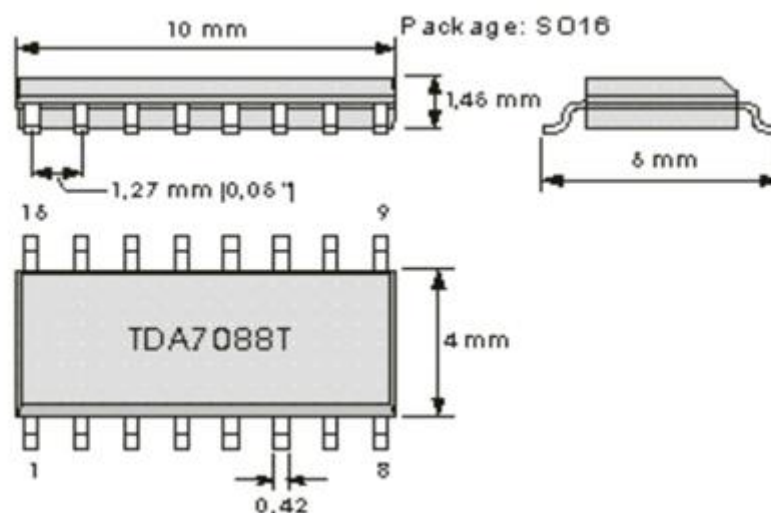

Figure 3.6: FM Transmitter

3.3_The radio receiver circuit

will depend mainly on the TDA7088T, as this circuit is designed for the purposes of monophonic radios and is characterized by the ability to search and select stations automatically, in addition to its small size and low energy use. Automatic tuning and therefore we do not need to use variable capacitors. Figure(3.7) below shown TDA7088T IC.



3.3.1- BB910: It is used instead of a variable capacitor, as its value changes based on the change in voltage on the 5.6 k resistance.

3.3.2_ capacitors, resistors and inductors.

3.4-The circuit mechanism

after pressing on the RUN button produces a positive pulse and we will push to set and then the 100nf capacitor starts charging and the voltage on pin 16 starts to increase after increasing it is

transferred through the 5.6k resistor and then to the BB910 diode after that inside the mixer which receives the signals via pin 11 after that To the demodulator, after pressing the Reset button, the capacitor discharges its charge and the voltage on pin 16 drops to zero. The receiver is reset to the lowest frequency and only after the RUN button passes the signal to an active filter and then amplifies and decodes the BC547 audio amplifier that is placed on its headphone output With a resistance of 16 ohms, the resistance R4 is intended to maintain low power consumption. Finally, a 20cm wire was used as a receiving antenna as shown below in the figure(3.8).

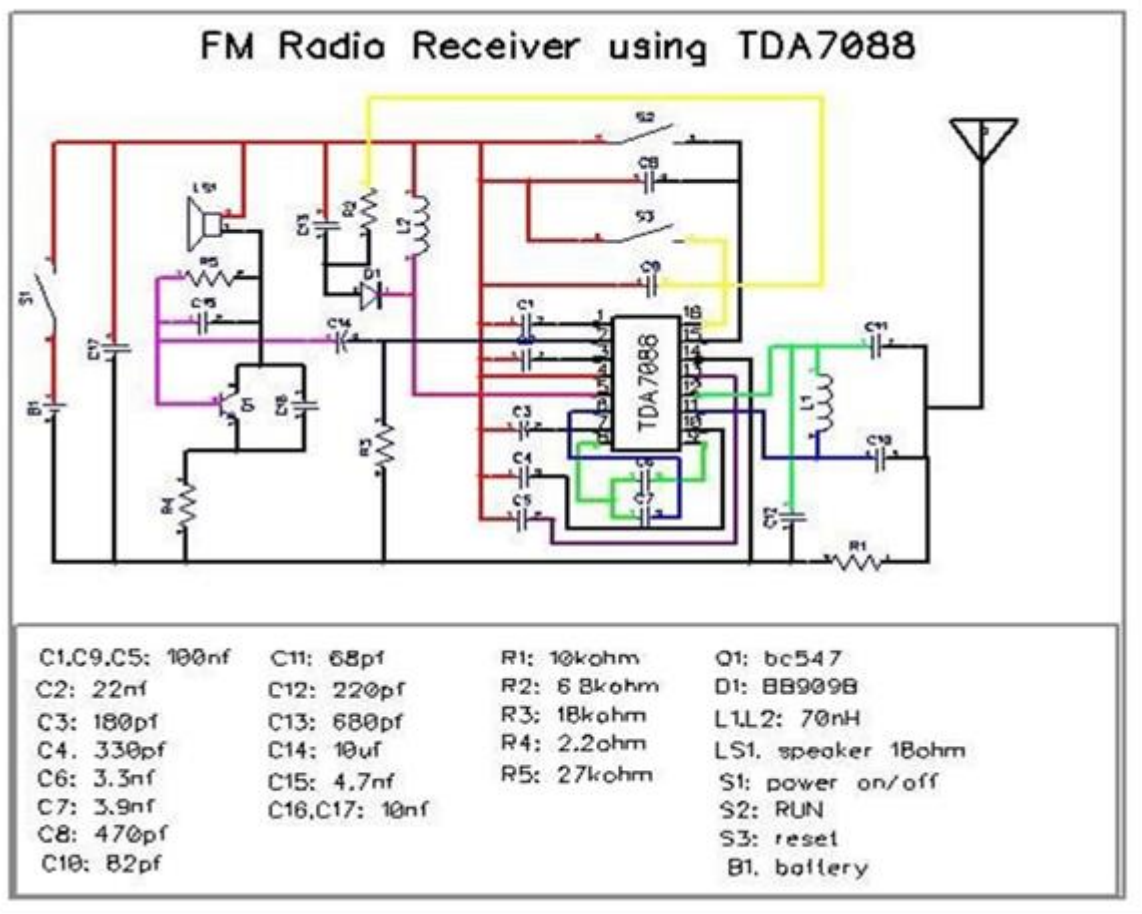

NOTE:

The above project has not been practically accomplished due to a malfunction in the integrated circuits, the lack of time and the difficulty of obtaining other integrated circuits, and because they are not available locally. Another idea was found with the same principle of work as the above project idea, which is as follows

This project consists of a transmitting circuit and a receiving circuit

3.5_Tools Used

3.5.1-LM386:chip is a very popular subwoofer chip that allows the user to amplify the sound, widely used, very popular. We will study the aspects of this chip, including the ends of its terminals and how to connect them to the circuit. This chip contains only 8 pins (pins) so it is an easy-to-use IC. The following figure shows the eight parts of the LM386 chip: The LM386 is a versatile chip. Only two resistors and capacitors are needed to make an amplifier, and the chip has options for controlling volume and amplification using switches, and it can also be converted into an oscillator capable of outputting sine waves or square waves. The actual output power you get will depend on the supply voltage and impedance (Impedance) the amplifier Remember that the gain limits the range of possible sound levels. For example, if your gain is set to 20, then the amplification range is 0 to 20. If your gain is set to 200, then the amplification range is 0 to 200Description and

functions of the terminals as per the datasheet in the following table:

Pin	Function
Pin 1 & 8	Terminals 1 and 8 represent the gain control of the amplifier (Gain) These are the terminals where you can adjust the gain by placing a resistor and a capacitor or capacitor between these two points in this circuit we are going to put a $10\mu\text{F}$ capacitor to get the highest voltage gain.
Pin 2&3	These are the ends of the audio input signal. These are the ends where you place the sound you want to amplify. Terminal 2 is the negative input – and 3 is the positive + input.
Pin 4	GND ground
Pin 5	Subwoofer output This is the station where the amplified audio signal is output.
Pin 6	Positive feeding of the amplifier
Pin 7	This terminal is usually left open or connected to the ground line. However, for better stability, a capacitor is added as this can prevent oscillations in the amplifier chip.

Notes:

1– Gain can be controlled by connecting a $10\ \mu\text{F}$ capacitor between pins 1 and 8. Without a capacitor between pins 1 and 8, the gain will automatically be set to 20. With a $10\ \mu\text{F}$ capacitor, the gain will be set to 200. The gain can be changed to any value between 20 and 200 by placing a resistor (or rheostat) in series with the capacitor. If your use is for industrial purposes, ask the experts how to add a set of additional capacitors to reduce noise at the amplifier's output.

2 – The chip has options for controlling the volume and increasing the volume using the keys, and it can also be converted into an oscillator capable of outputting sine waves or square waves.

3.5.2- LM4872 amplifier: is a micro SMD element that is characterized by its low power consumption, accurate size, and the ability to control signal gain.

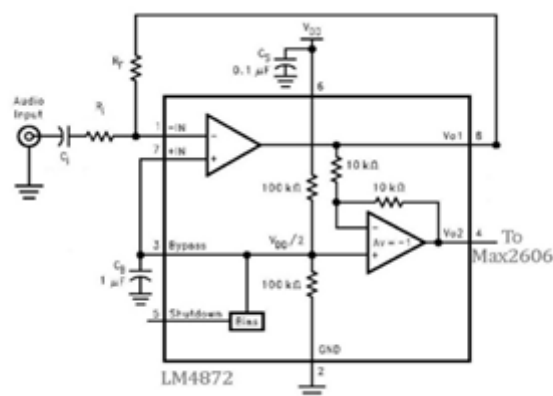

Figure 3.10: The internal structure of the audio amplification circuit LM4872

R_f : The feedback resistance, which determines the amount of gain in combination with the resistance R_i

R_i : Input impedance, to determine the gain, used as a high-pass filter in combination with the capacitor C_i

C_i : Input Capacitor, used to block the continuous vehicle from the input and also as a high-pass

filter with R_i

C_s : Feed capacitor, which is a bypass capacitor to block vibrations that may result from feeding.

C_b : An additional pass-through capacitor is also used for the same purpose

3.6 Methodology

The method of work is divided into three parts:

The first part is the transmitter

The first sound is captured by the microphone, by aux or any other method, and the audio signal is filtered through a set of capacitors and resistors, then the sound is transmitted to the amplifier that amplifies the signal to be sent to a LM386 piece that converts the sound signal into light and this light is sent through medium modes.

Result and Discussion

4.1 Results

Working of project

The method of work is the first thing, the person's voice is transformed from analog to digital through the microphone and then through the expander c_1 that works as a filter, after that the sound goes to the resistance that works to reduce the voltage values and adjust them so that the sound fits with the signal that will go to the IC LM386 and its guest is to amplify the sound signal. There are a group of resistors and amplifiers connected with the IC so that it is effective for the work of the IC, as it connects the ground with Ben 4 to adjust the audio signal. Then the sound goes to the LM4872, which amplifies the sound and sends it to the receiving circuit. When the sound is received, it enters a variable resistance that reduces and coordinates the voltage values so that we can use it in the receiving circuit. Then the sound goes to the ICE, which processes the sound. Then the sound passes through a number of amplifiers, which work in the form of filters that purify the sound and bring it out through the speaker. The sound is from the digital to the unlock so that the human ear can hear it, where the human ear can hear sounds that range between (20-20kh)

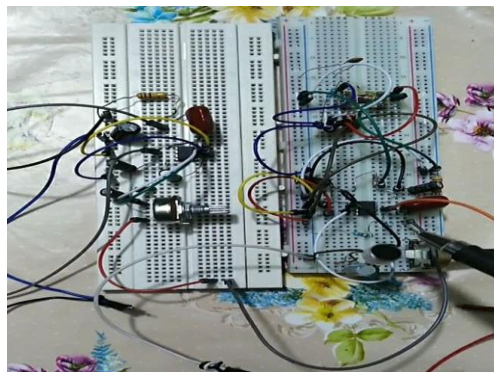

Figure 4.1: Transmitter and Receive Circuits

4.2 Discussion

In this project, a device was designed and implemented to help people who are unilaterally deaf. This device consists of two parts; the first part is a transmission circuit installed on the deaf ear of the affected person. Its role is to receive sound waves from the surrounding environment and then process them and send them to the flexural part of the circuit, which is represented by the receiving circuit, where it receives the coming sound waves from the transmitter circuit after processing it, thus providing an excellent solution for people who suffer from the problem of unilateral deafness.

5.1_ Conclusion

At a time when health care has become the first basic criteria in order to measure the degree of progress of peoples and their civilization, the great importance of biomedical engineering, which is now conquering the whole world with its solutions provided to serve humanity at the engineering and biomedical levels, was necessary. One of the health cases that suffer from a lack of therapeutic solutions is the case of unilateral deafness (SSD), as the therapeutic solutions provided for this case are either surgical, which are dangerous and expensive, or engineering prosthetic solutions that are few in spread and expensive, and since the biomedical engineer has the paramount role in the search for remedial solutions and at the lowest costs, the idea of this project was reached with a first technique, as we have seen, which is an illustrative technique. The method was to use surface-developed elements (SMD) that are not available locally, so it was replaced by another method similar to the main idea with the same results desired to be obtained for the purpose of helping this category of people, facilitating their daily lives and their integration into society.

5.2_ The future steps for the development of this project

- We can use Bluetooth technology with the Android application for mobile devices by placing the Bluetooth headset, where we can replace the use of the future by placing the Bluetooth headset from the mobile device, with the help of an Android application for the idea of the project and the device, which receives the frequency sending device.
- A better communication technique can be proposed by considering environmental effect during communication. We will also work to raise the efficiency of communication and increase the accuracy of the received voice. Change the type of communication between the transmitting and receiving circuit from a wired connection to a wireless connection that allows ease of use for infected persons.
- Since the aesthetic factor plays the largest role for women, the woman affected by the condition (SSD) has a share of the idea of developing this project by designing special-shaped women's earrings that contain the transmission and reception circuits.
- The transmission and reception circuits can also be designed in a way that allows us to By placing it on the frame of medical glasses, as in some hearing aids, and last but not least, we hope from God Almighty that you have succeeded in achieving our goal of this project.

References

1. Johnson JL, White KR, Widen JE, Gravel JS, James M, Kennalley T, et al. A multicenter evaluation of how many infants with permanent hearing loss pass a two-stage otoacoustic emissions/automated auditory brainstem response newborn hearing screening protocol. *Pediatrics*. 2005;116(3):663–72.
2. Van de Heyning P, Tavora-Vieira D, Mertens G, Van Rompaey V, Rajan GP, Muller J, et al. Towards a unified testing framework for single-sided deafness studies: a consensus paper. *Audiol Neurootol*. 2016;21(6):391–8.
3. Hussain SSM. Hearing loss in the 4-8 kHz range following tympanic membrane perforation from minor trauma. *Clin Otolaryngol Allied Sci*. 1995 Jun; 20:211-2.
4. Pedley A J, Kitterick P T. Contralateral routing of signals disrupts monaural level and spectral cues to sound localisation on the horizontal plane. *Hear Res*. 2017;353:104–111.
5. Blauert J. London, England: The MIT Press; 1997. *Spatial Hearing: The Psychophysics of Human Sound Localization*.
6. Sinopoli, T. (2003). "Single Sided Deafness: Issues and Alternatives", *Audiologyonline*.
7. WHO 2014. "Fact Sheet Report: Deafness and Hearing Impairment."
8. <http://www.werathah.com/deafness/anatomy.htm>

9. <http://www.starkey.com>
10. <http://www.medel.com/>
11. <https://www.electronics-lab.com/project/fm-transmitter-using-max4467-max2606>
12. <https://electronics.tocircuit.com>
13. <https://sahak21.tripod.com/projek/fmrx/minifm.htm>
14. <http://bijocircuits.blogspot.com/2014/05/laser-communication-transmitter.html?m=1>